

PROBLEM 1 – 15 points

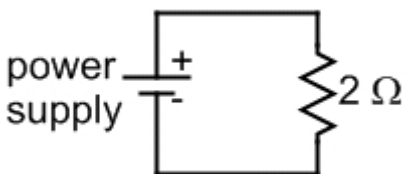

[5 points] (a) In the Ohm's Law experiment a power supply is connected to a resistor, as shown in the circuit diagram above. Assuming the resistance of the resistor is always $2\ \Omega$, and that the voltage of the power supply is varied from $-5\ \text{V}$ to $+5\ \text{V}$, plot a graph of the current through the resistor as a function of the power-supply voltage.

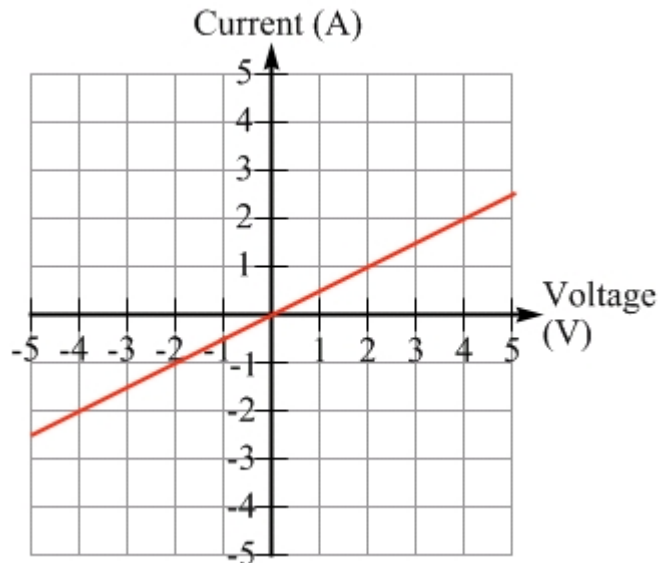

$$\Delta V = IR, \quad \text{so} \quad I = \frac{\Delta V}{R} = \frac{1}{2\Omega} \Delta V$$

The graph should have a slope of $\frac{1}{2\Omega}$

[5 points] (b) A $3\ \Omega$ resistor is now connected in series with the original resistor and the power supply. Draw the circuit diagram for this circuit, and briefly discuss how the current through the $2\ \Omega$ resistor in the new circuit compares to the current through the $3\ \Omega$ resistor.

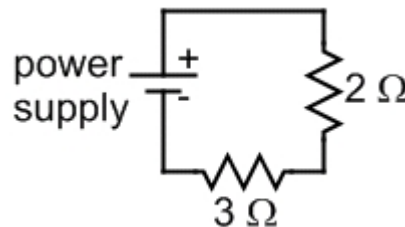

The resistors are connected in series so they must have the same current.

[5 points] (c) If the voltage of the power supply is again varied from $-5\ \text{V}$ to $+5\ \text{V}$, plot a graph of the current through the $2\ \Omega$ resistor as a function of the power-supply voltage for the circuit in part (b), when the $3\ \Omega$ resistor is in series with the $2\ \Omega$ resistor and the power supply.

$$\Delta V = IR, \quad \text{so} \quad I = \frac{\Delta V}{R_{eq}} = \frac{1}{2\Omega + 3\Omega} \Delta V$$

The graph should have a slope of $\frac{1}{5\Omega}$

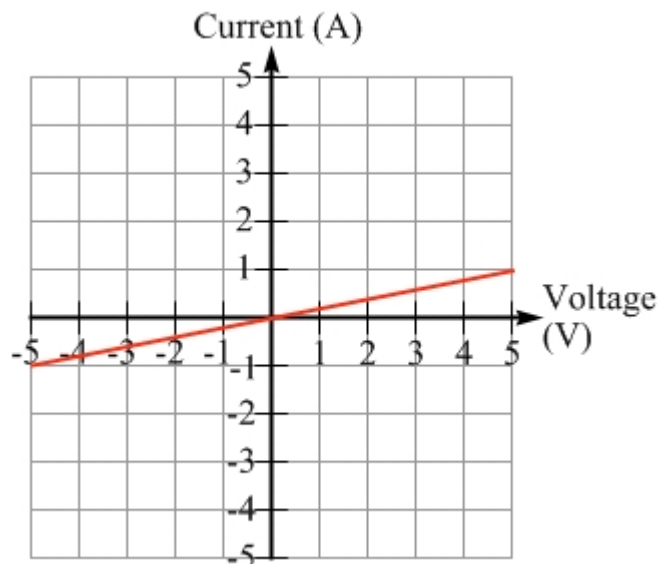

PROBLEM 2 – 15 points

Three resistors, of resistance $4.0\ \Omega$, $3.0\ \Omega$, and $6.0\ \Omega$, are connected in the circuit shown at right with a battery that has a voltage of 18 volts.

[3 points] (a) Determine the equivalent resistance of this circuit.

The $3.0\ \Omega$ and $6.0\ \Omega$ resistors are in parallel, with a combined resistance of $2.0\ \Omega$. That can

be found from: $\frac{1}{R_{eq}} = \frac{1}{3} + \frac{1}{6} = \frac{2}{6} + \frac{1}{6} = \frac{3}{6} = \frac{1}{2} \Rightarrow R_{eq} = 2.0\ \Omega.$

The parallel combination is in series with the $4.0\ \Omega$ resistor, for a total resistance of:

$$R_{total} = 4.0\ \Omega + 2.0\ \Omega.$$

[3 points] (b) Calculate the current through the $3\ \Omega$ resistor.

Let's first find the total current in the circuit: $I = \frac{\Delta V}{R_{total}} = \frac{18\ \text{volts}}{6.0\ \Omega} = 3.0\ \text{A}.$

The current splits, with $2/3$ going through the $3.0\ \Omega$ resistor, so it has a current of $2.0\ \text{A}$.

Another method is to find the voltage across the $4.0\ \Omega$ resistor: $\Delta V_4 = IR = (3\ \text{A})(4\ \Omega) = 12\ \text{V}.$

This leaves $6.0\ \text{V}$ for the parallel combination, giving a current through the $3.0\ \Omega$ resistor

of: $I_3 = \frac{\Delta V_3}{R} = \frac{6.0\ \text{volts}}{3.0\ \Omega} = 2.0\ \text{A}.$

[4 points] (c) Could you add a $5\ \Omega$ resistor to the circuit so that some current passes through it, while at the same time the currents through the original three resistors are unaffected? If so, re-draw the circuit to show how this could be done. If not, explain why not.

It can be done. This is how things work in your house. Turning on a lamp in your house does not affect the current through something else, because the lamp is connected in parallel. If we add the $5\ \Omega$ resistor in parallel with the battery the original set of resistors still has $18\ \text{V}$ across it and is unaffected. The overall resistance of the circuit goes down, and the current from the battery goes up, but all the extra current goes through the $5\ \Omega$ resistor.

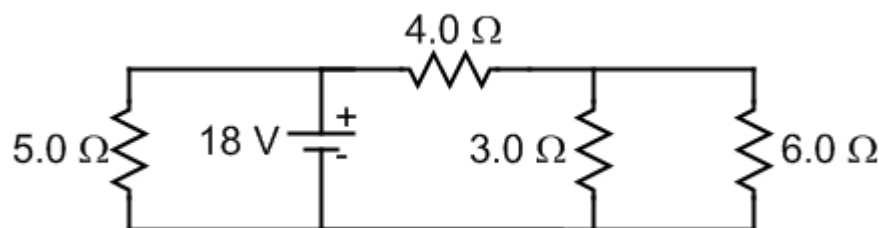

[5 points] (d) Could you add a $5\ \Omega$ resistor to the original circuit so that one or more of the currents through the original three resistors increases? If so, re-draw the circuit to show how this could be done. If not, explain why not.

There are at least four ways this can be done. Method 1 - as shown in the diagram, the $5\ \Omega$ resistor could be placed in parallel with the $3\ \Omega$ and $6\ \Omega$ resistors. Although this decreases the current through those resistors the overall circuit resistance is lower so more current

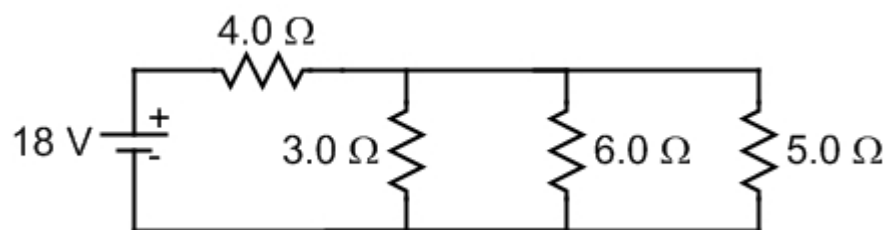

passes through the $4\ \Omega$ resistor. Method 2 – put the $5\ \Omega$ resistor in parallel with the $4\ \Omega$ resistor, increasing the current to the $3\ \Omega$ and $6\ \Omega$ resistors. Method 3 - put the $5\ \Omega$ resistor in series with the $3\ \Omega$ resistor, increasing the current to the $6\ \Omega$ resistor. Method 4 - put the $5\ \Omega$ resistor in series with the $6\ \Omega$ resistor, increasing the current to the $3\ \Omega$ resistor.

PROBLEM 3 – 10 points

Five identical light bulbs, and four switches, are connected in the circuit shown. Assume the resistance of each bulb is constant no matter what the current is through it.

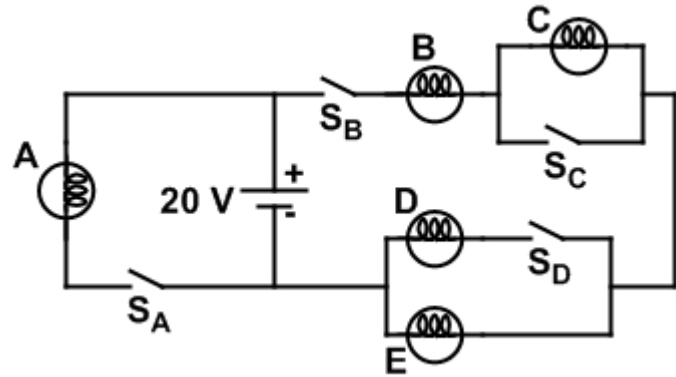

[4 points] (a) What is the minimum number of switches that should be closed so that at least one light bulb will turn on?

- [] 0 [X] 1 [] 2 [] 3 [] 4

Justify your answer. If you think one or more switches need to be closed then specify which need to be closed.

If we close switch A, bulb A will turn on. Alternatively, we could close switch B and bulbs B, C, and E would turn on. All we need to do is to have a complete loop for the current, and having one on the right or the left of the circuit is all we need.

[3 points] (b) Explain which switches should be closed to maximize the brightness of bulb C. Are there any switches that, whether they are open or closed, do not affect the brightness of bulb C?

Switch B must be closed to get any current at all to C. Switch D must also be closed. This lowers the resistance of the right-hand side of the circuit, increasing the current to bulb C.

Switch A can be open or closed, it doesn't matter. The right-hand side still gets the full battery voltage across it no matter what's going on with bulb A.

Switch C should be left open – closing it causes C to turn off because all the current would flow through switch C (which we assume to have zero resistance when closed) if it is closed.

[3 points] (c) If every switch is closed, rank the bulbs based on their brightness, from brightest to dimmest.

- [] All bulbs are equally bright [] $A > B = D = E > C$ [] $A > B = C > D = E$
 [] $A = B > D = E > C$ [X] $A > B > D = E > C$ [] $A = B = C > D = E$ [] $A > B > C = D = E$

With all switches closed bulb A is the brightest because it is the only bulb that gets the full battery voltage. B is next brightest, because all the current on the right side passes through B. D and E are equally bright, and dimmer than B, because they each get half the current that passed through B. C is off, because closing switch C diverts the current through the switch.

PROBLEM 4 – 15 points

Three batteries are connected in a circuit with three resistors, as shown in the diagram. The currents in two of the branches are known and marked correctly on the diagram. There are three unknowns in the circuit: the resistance R of one resistor; the current through the 2-volt battery; and the emf of the battery in the middle branch of the circuit.

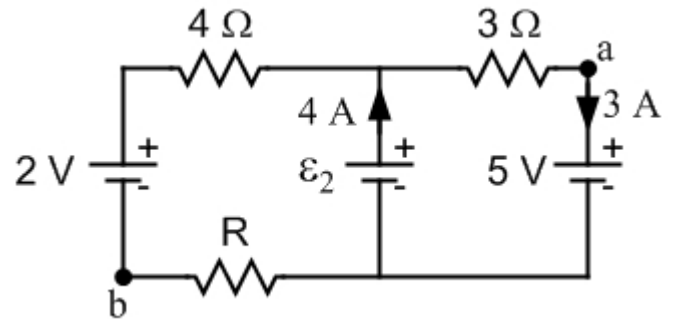

[9 points] (a) Solve for the three unknowns in the problem. Note that you should not have to do lots of algebra.

Apply the junction rule to the junction at the top. A current of 4 A comes in to that junction, so a total of 4 A must go out. The current to the right is 3 A, so the current going left must be 1 A. It flows left and then down through the 2 V battery.

To find the emf of the battery in the middle branch, apply the loop rule to the inside loop on the right. Going around the loop clockwise gives:

$$+\varepsilon_2 - (3 \text{ A})(3 \Omega) - (5 \text{ V}) = 0 \quad \text{so} \quad \varepsilon_2 = 14 \text{ V}$$

To find the resistance R , apply the loop rule to the inside loop on the left (you could also go all the way around the outside). Going counter-clockwise gives:

$$+14 \text{ V} - (1 \text{ A})(4 \Omega) - (2 \text{ V}) - (1 \text{ A})(R) = 0 \quad \text{so} \quad R = \frac{14 \text{ V} - 4 \text{ V} - 2 \text{ V}}{1 \text{ A}} = 8 \Omega$$

The current through the 2-volt battery has a magnitude of 1 A, and is directed [] up [**X**] down through the battery.

The resistance R is equal to 8 Ω.

The emf of the battery in the middle branch of the circuit is 14 V.

[3 points] (b) What is the potential difference, $V_a - V_b$, between points a and b in the circuit?

One way to do this is to say that the potential at point b is $V_b = 0$. Going from point b through the 8Ω resistor, with the current, the potential drops by $1 \text{ A} \times 8 \Omega$ to -8 V . From there go up through the 5 V battery, raising the potential 5 V to -3 V . Thus $V_a = -3 \text{ V}$ compared to $V_b = 0$, so $V_a - V_b = -3 \text{ V}$. Check your answer by going a different route from b to a .

[3 points] (c) Which resistor has the largest power dissipated in it? How much power is dissipated in that resistor?

For resistors use $P = I^2 R$. The 3Ω resistor has a power of $(3 \text{ A})^2(3 \Omega) = 27 \text{ W}$. The 8Ω resistor, which has more power than the 4Ω resistor because they have the same current, has a power of only $(1 \text{ A})^2(8 \Omega) = 8 \text{ W}$. Thus the 3Ω resistor has the most power, 27 W .